

ITEM	QTY	UNITS	DESCRIPTION	MATERIAL	MANUFACTURER
1	1	EA	8' DIA. BASE PAN	STEEL	
2	1	EA	4'-8" DIA. DISK (CAST INSIDE TREE FOR MOUNTING)		
3	8	EA	3/8-16 THREADED STUD X 3" LG, GRADE B7	ZINC PLATED STEEL	McMASTER CARR OR EQ
4	8	EA	3/8" FENDER WASHER	ZINC PLATED STEEL	McMASTER CARR OR EQ
5	8	EA	HEX HEAD NUT 3/8"-16	ZINC PLATED STEEL	McMASTER CARR OR EQ



FINISH TO BE POWDER COATED MATTE BLACK

VIBRATION DAMPER PAD

GUSSET EVERY 1'

2" CONCRETE

STEEL DECK

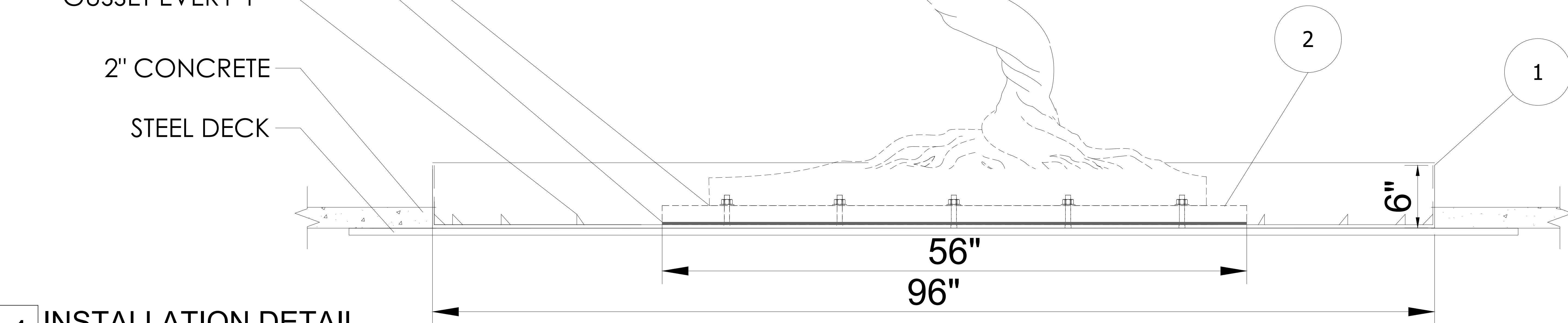

# 1 INSTALLATION DETAIL

DRAWING SCALE 1:05

**SAVOY**  
STUDIOS

13908 N. LOMBARD ST.  
PORTLAND, OR 97203  
P 503.282.5095  
F 503.282.2183  
WWW.SAVOYSTUDIOS.COM



PROJECT CLIENT  
NORWEGEN CRUISE LINE HOLDINGS LTD.

PROJECT TITLE  
REGENT GRANDEUR  
FEATURE SCULPTURE V3

JOB NUMBER  
22-043

SHEET TITLE  
CHEERY TREE  
BASE

ESTIMATED WEIGHT  
MAX ESTIMATED WEIGHT

GENERAL NOTES  
UNLESS OTHERWISE NOTED:  
DIMENSIONS: ALL DECIMAL DIMENSIONS MAY BE ROUNDED TO NEAREST FRACTION FOR EASIER FABRICATION, NO STANDARD TOLERANCES

ENGINEERING: ALL STRUCTURAL ENGINEERING FINAL STAMP TO BE APPLIED TO AS-BUILT DRAWING SET AND PROVIDED BY OTHERS.

FINISHES: ALL FINISHES AND THE APPLICABLE SURFACES TO BE DETERMINED BY CUSTOMER

**PROPRIETARY AND CONFIDENTIAL**  
THE INFORMATION CONTAINED IN THIS DRAWING IS THE SOLE PROPERTY OF SAVOY STUDIOS. ANY REPRODUCTION IN PART OR AS A WHOLE WITHOUT THE WRITTEN PERMISSION OF SAVOY STUDIOS IS PROHIBITED.

DRAWN:	GDL	DATE:	03-06-2023
CHECKED:	KL	DATE:	
PROJECT MGR: KEIR-LEGREE			
REV	SIZE	DRAWING SCALE	SHEET OF
R1	D-(36X24)	N/A	1_2

ITEM	QTY	UNITS	DESCRIPTION	MATERIAL	MANUFACTURER
1	1	EA	8' DIA. BASE PAN	STEEL	
2	1	EA	4'-8" DIA. DISK (CAST INSIDE TREE FOR MOUNTING)		
3	8	EA	3/8"-16 THREADED STUD X 3" LG, GRADE B7	ZINC PLATED STEEL	McMASTER CARR OR EQ
4	8	EA	3/8" FENDER WASHER	ZINC PLATED STEEL	McMASTER CARR OR EQ
5	8	EA	HEX HEAD NUT 3/8"-16	ZINC PLATED STEEL	McMASTER CARR OR EQ

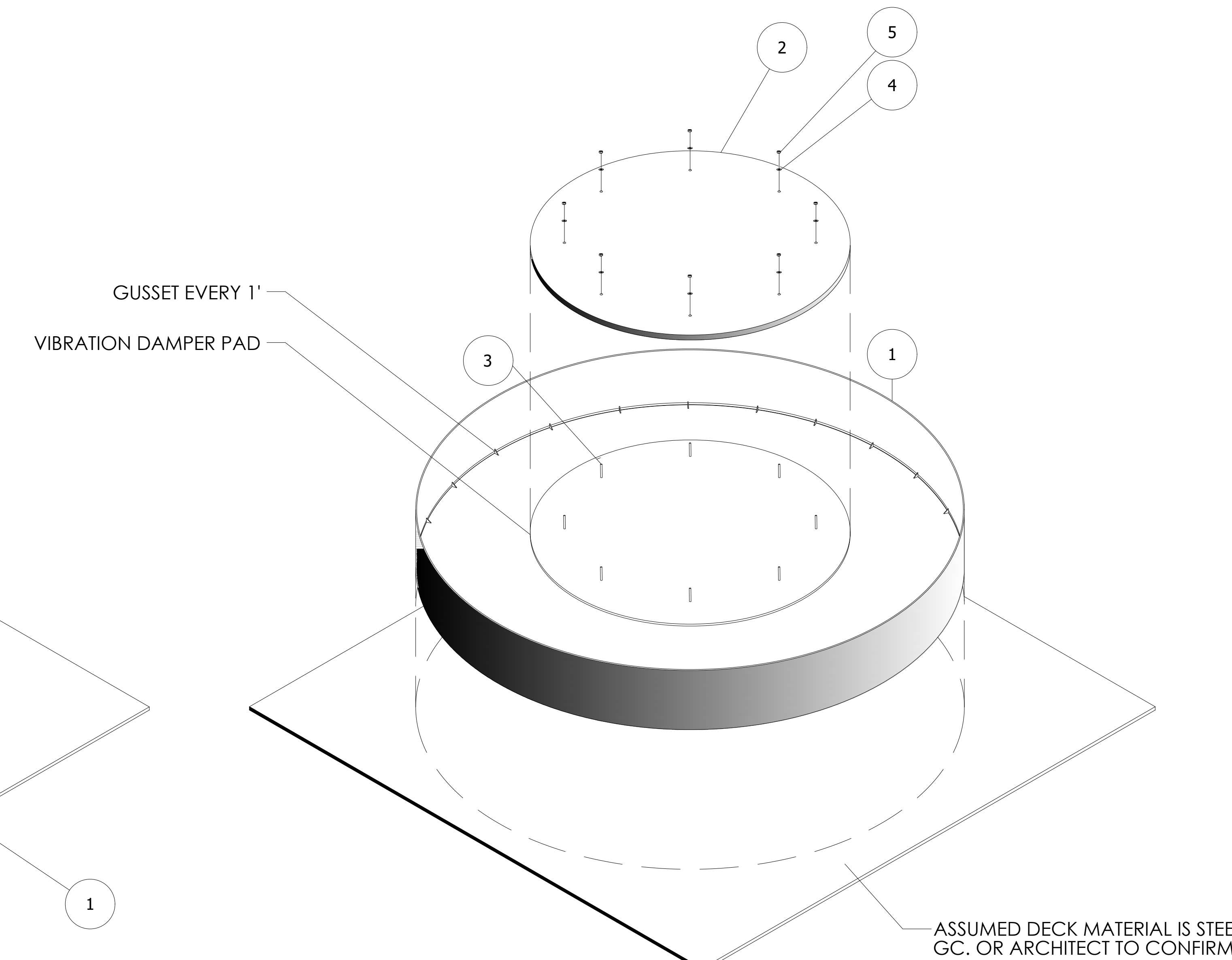
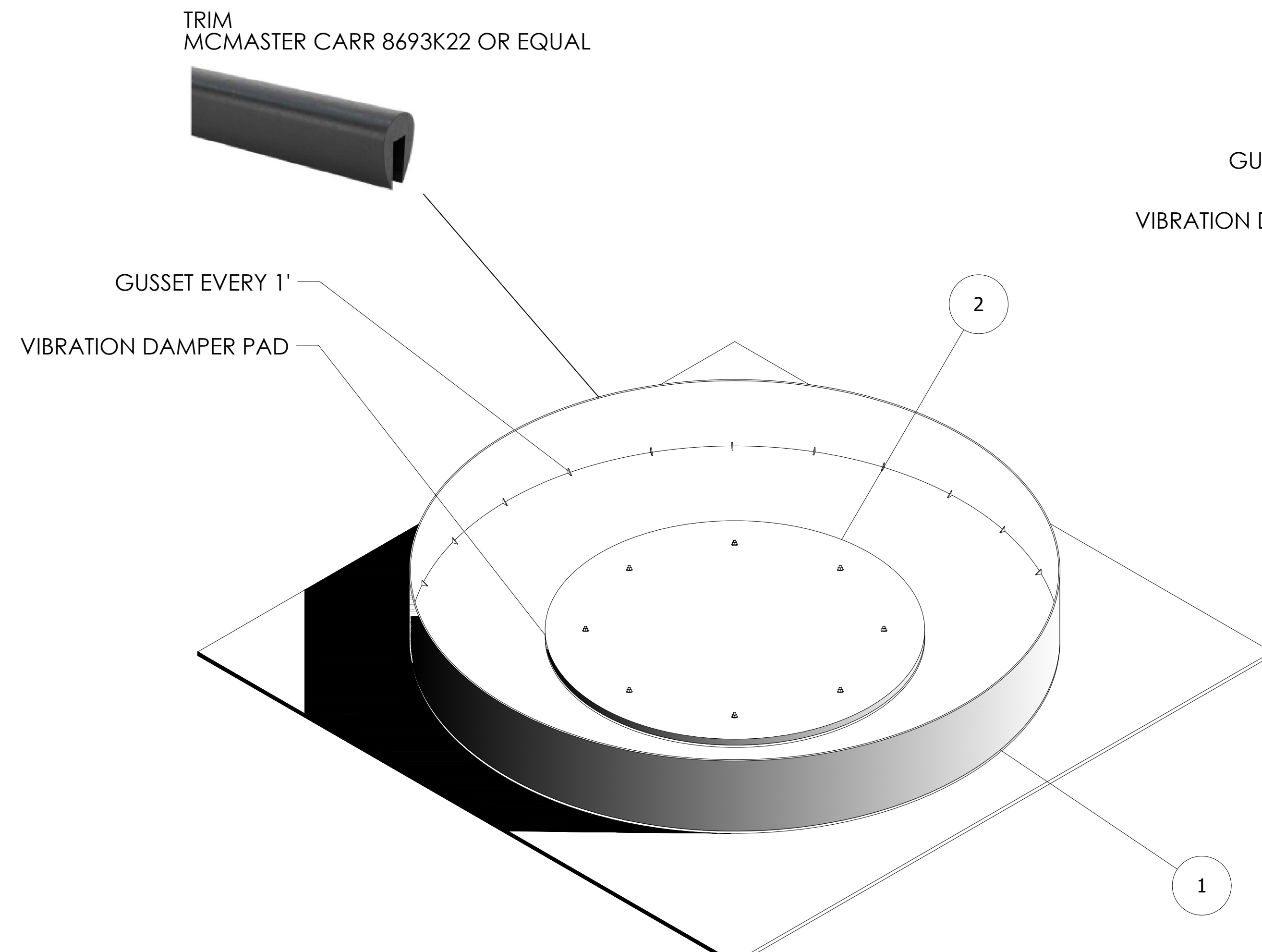

# 1 INSTALLATION DETAIL

DRAWING SCALE 1:10

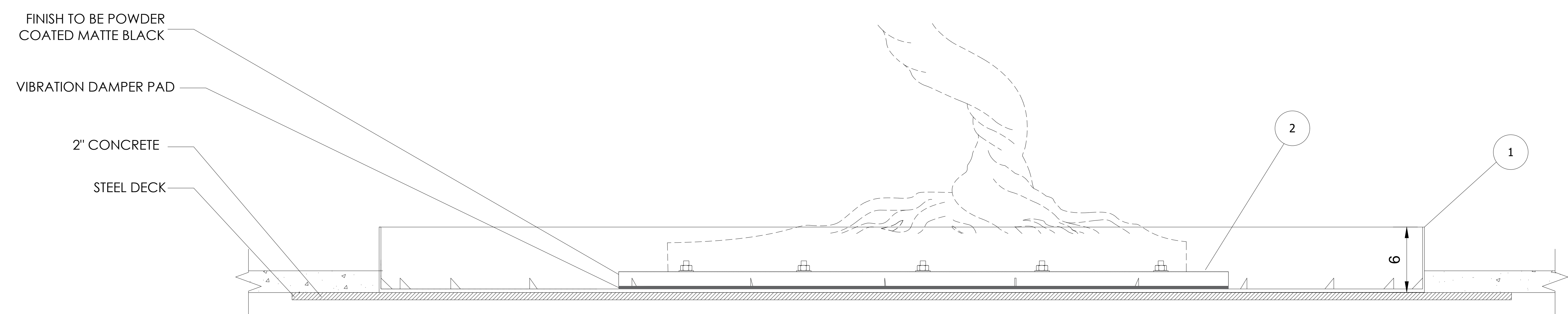

# 2 CUT SECTION OF INSTALLATION

DRAWING SCALE 1:05

**SAVOY**  
STUDIOS

13908 N. LOMBARD ST.  
PORTLAND, OR 97203  
P 503.282.5095  
F 503.282.2183  
WWW.SAVOYSTUDIOS.COM



PROJECT CLIENT  
**NORWEGEN CRUISE LINE HOLDINGS LTD.**

PROJECT TITLE  
**REGENT GRANDEUR FEATURE SCULPTURE V3**

JOB NUMBER  
**22-043**

SHEET TITLE  
**CHEERY TREE BASE**

ESTIMATED WEIGHT

MAX ESTIMATED WEIGHT

GENERAL NOTES

UNLESS OTHERWISE NOTED:  
DIMENSIONS: ALL DECIMAL DIMENSIONS MAY BE ROUNDED TO NEAREST FRACTION FOR EASIER FABRICATION, NO STANDARD TOLERANCES

ENGINEERING: ALL STRUCTURAL ENGINEERING FINAL STAMP TO BE APPLIED TO AS-BUILT DRAWING SET AND PROVIDED BY OTHERS.

FINISHES: ALL FINISHES AND THE APPLICABLE SURFACES TO BE DETERMINED BY CUSTOMER

**PROPRIETARY AND CONFIDENTIAL**  
THE INFORMATION CONTAINED IN THIS DRAWING IS THE SOLE PROPERTY OF SAVOY STUDIOS. ANY REPRODUCTION IN PART OR AS A WHOLE WITHOUT THE WRITTEN PERMISSION OF SAVOY STUDIOS IS PROHIBITED.

DRAWN: GDL DATE 03-06-2023

CHECKED: KL DATE:

PROJECT MGR: KEIR-LEGREE

REV	SIZE	DRAWING SCALE	SHEET	OF
R1	D-(36X24)	N/A	2	2